

R 6499

Instruction Book

PFAFF[®] **141; 143; 145; 151; 153**

541; 543; 543-712; 545; 555

Single-needle flatbed sewing machines
and

PFAFF[®] **142; 144; 146**

542; 542-748/01; 544; 546; 546-748/01

Two-needle flatbed sewing machines

PFAFF INDUSTRIEMASCHINEN GMBH KAISERSLAUTERN

Contents

	Page
1. General	3
2. Fundamentals of machine operation	3
3. Cleaning and oiling	4
4. Winding the bobbin	6
5. Changing the bobbin and threading the bobbin case	7
6. Selecting the correct needle	8
Needle systems	8
Needle point styles	8
Needle and thread sizes	8
7. Changing the needle	10
8. Threading the needle	10
9. Drawing up the bobbin thread	11
10. Regulating the thread tensions	11
Adjusting the upper tension	11
Adjusting the lower tension	12
11. Regulating the stitch length	12
12. Regulating the pressure on the material	13
13. Cleaning the sewing hook	14
14. The safety clutch	15
Additional instructions for Pfaff machines 141-705/03 and 141-705/03-725/01	16–18
15. Regulating the stitch length	17
16. Changing the feed gears	18
17. Adjusting the trimmer (Pfaff 141-705/03-725/01 only)	19
18. Operating the trimmer	20
Additional instructions for Pfaff machines 143-705/03	21
19. Regulating the stitch length	21
Additional instructions for Pfaff machines 145 and 545	22–24
20. Exchanging the alternating pressers	22
21. Lubricating the machine	24
22. Setting the foot lift	24
Additional instructions for Pfaff machines 151, 153 and 555	24
Additional instructions for Pfaff machines 142, 144, 146, 547, 544, 546, 542-748/01 and 546-768/01	25–26
23. Threading the needles	25
24. Adjusting the puller feed of the Pfaff 542-748/01	26
Additional instructions for Pfaff machines 543-712/01 and 543-712/02	27
25. Threading the needle of the Pfaff 543-712	27
Additional instructions for Pfaff machines 548-748/01	28–29
26. Setting the foot lift	28
27. Adjusting the puller feed	29
Additional instructions for Pfaff machines fitted with thread puller/trimmer 900/... , automatic presser foot lifter -910/.. and reverse-sewing mechanism -911/..	30
28. Pedal operation	30
Guards	31–33
Trouble shooting	34

1. General

Since the operation of the machines listed on the title page is more or less the same the general instructions compiled in this book apply to all of them.

Additional instructions for the Pfaff 141-705-03; 141-705/03-725/01; 142; 143-705/03; 144; 145; 146; 542; 542-748/01; 543-712/..; 544; 545; 546; 546-748/01; 555 and thread trimmer -900.. appear at the back of this booklet.

We reserve the right to make alterations serving progress. The illustrations in this book are also subject to change.

It is recommended to run these machines at the following top speeds:

Pfaff 143	3 000 s.p.m.	Pfaff 146	2 300 s.p.m.
Pfaff 141 and 144	2 900 s.p.m.	Pfaff 545 H3; 555 H3	2 100 s.p.m.
Pfaff 142	2 800 s.p.m.	Pfaff 546 H2	1 900 s.p.m.
Pfaff 151 and 544	2 700 s.p.m.	Pfaff 546 H3	1 800 s.p.m.
Pfaff 153 and 542	2 600 s.p.m.	Pfaff 545 H4; 555 H4	1 700 s.p.m.
Pfaff 543	2 500 s.p.m.	Pfaff 546 H4	
Pfaff 145 and 541	2 400 s.p.m.	and 543-712/..	1 400 s.p.m.

When sewing tightly woven and heavily dressed materials, the sewing speed should be reduced in order to prevent overheating of the needle.

The maximum speed of two-needle machines decreases as the needle gauge increases. The maximum speeds which can be attained with machines fitted with special attachments or trimming mechanisms are often far below the recommended top speeds because the nature of work and the thickness of the material tend to limit the machine's capacity. If the maximum speed is exceeded, trouble may develop chiefly in the trimming mechanism.

To avoid trouble in the mechanism, run the machine at about 75 per cent of its top speed until the parts which are in movable contact have become thoroughly glazed by their action upon each other. This should normally be the case after about two weeks' constant use.

All machines are regularly equipped with a fixed pulley which is cast in one with the balance wheel. If desired, however, these machines can be supplied with a disengageable pulley.

If fitted with the latter type pulley, the machine is dispatched with the sewing mechanism disengaged. To engage this mechanism for sewing, hold the balance wheel steady with your left hand and turn the large lock nut clockwise.

2. Fundamentals of machine operation

Before you put the machine in operation for the first time, carefully remove all dust which has accumulated in transit and oil the machine thoroughly (see Chapter 3).

Oil the machine only with Pfaff sewing machine oil which is non-resinous and acid-free. Check to make sure the finger, take-up lever and belt guards are properly fitted.

Never run a threaded machine unless you have fabric under the presser foot or the vibrating presser.

Before you start sewing, lay both threads back under the presser foot.

To prevent thread jamming, hold both thread ends until the machine has made a few stitches.

Do not pull the material during sewing; the machine will feed the fabric automatically. Use needles of the correct system only (see Chapter 6).

Never use rusty needles.

Use high-quality threads only.

Always bring the take-up lever to its highest point before you remove the material.

3. Cleaning and oiling

Careful cleaning and regular oiling will increase the service life of your machine.

After you have removed the dust which has accumulated on the machine in transit, take a clean rag and remove the grease from all nickel-plated and polished parts. Apply a few drops of kerosene to all oiling points marked with dash lines in Figs. 1, 2 and 3, raise the presser foot, unthread the needle, remove the bobbin case and let the machine run briefly. Apply a few drops of **Pfaff sewing machine oil No. 280-1-120 122** to all points of friction.

While these points of friction should be oiled twice a week, the sewing hook must be oiled each day the machine is in operation. Make particularly sure that oil is applied to oilhole **R** (Fig. 4).

Although the bevel gears are enclosed in cases and require no special maintenance, it is recommended to replace the old grease by Pfaff grease No. 280-1-120 243 once a year. Owing to the special lubricating properties of this grease, the flanks of the bevel gear teeth should be greased only lightly.

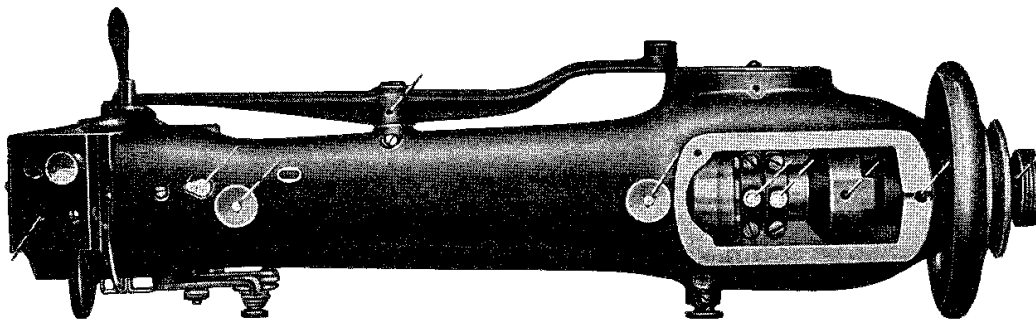

Fig. 1

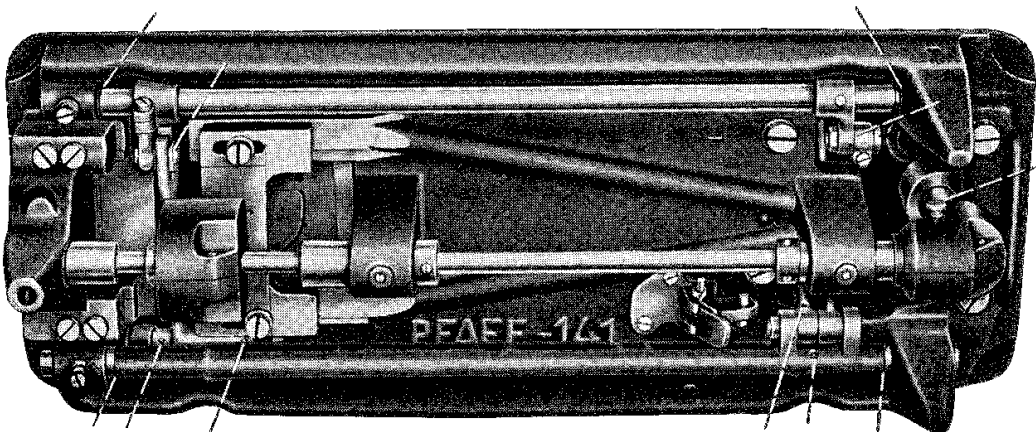

Fig. 2

From time to time remove the needle plate after taking out set screws **14** and **15** (Fig. 4) and remove the lint which has accumulated underneath. It is recommended at the same time to dismantle the sewing hook and clean it thoroughly (see Chapter 13). In replacing the needle plate make sure that position finger **F** (Fig. 13) on the bobbin case base enters slot **P** on the underside of the needle plate.

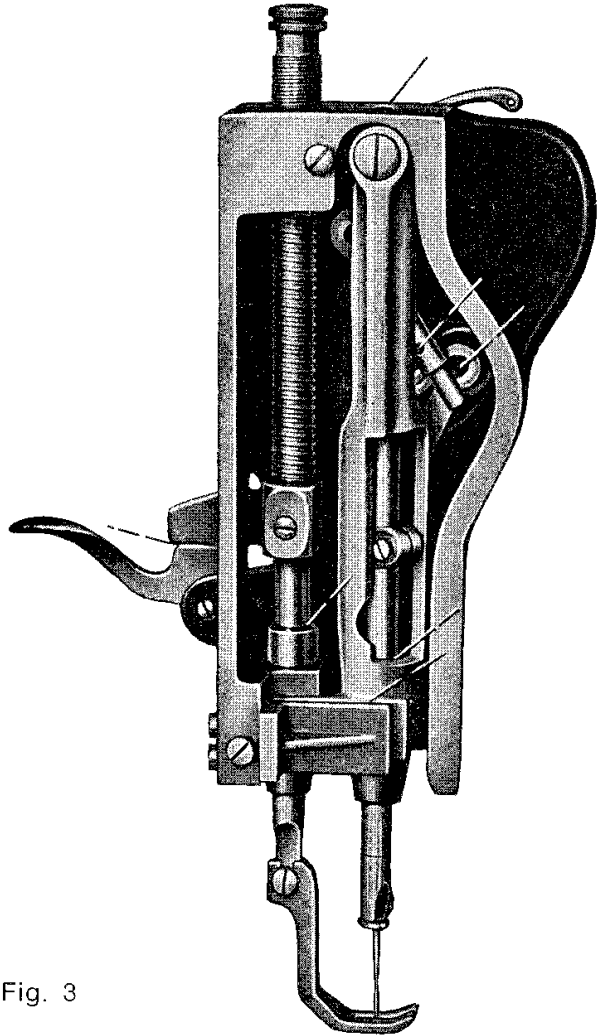

Fig. 3

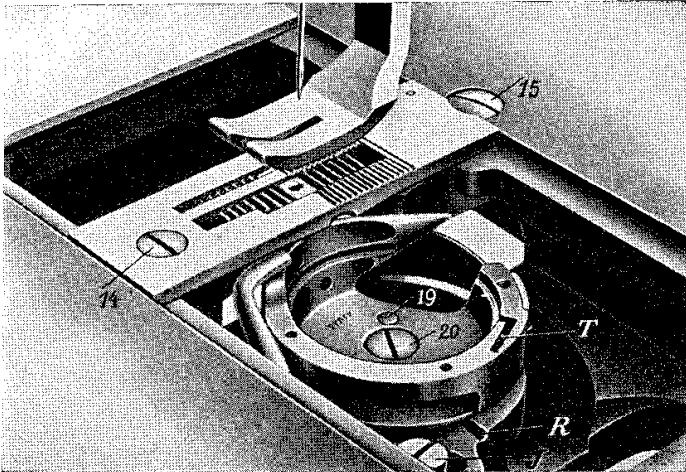

Fig. 4

4. Winding the bobbin

Place a spool of thread on pin **1** (Fig. 5) and pass the thread from left to right through eyelet **2**, clockwise around and between tension discs **3** and from the inside through the slot in the bobbin. Wind a few turns of thread on the bobbin and place the latter on spindle **4**. Start the bobbin winder by pressing down lever **5**. The bobbin is wound automatically while the machine is sewing. When a sufficient amount of thread has been wound on the bobbin, a latch stops the bobbin winder.

The amount of thread to be wound on the bobbin is regulated by screw **6**.

Turn this screw clockwise for more thread, or counter-clockwise for less thread.

If the thread should pile up at one end of the bobbin, adjust the position of the bobbin winder tension sideways, as may be required. To do this, loosen screw **7**, adjust the tension and tighten the set screw again.

The tension on the thread is regulated by turning nut **8**.

Make sure the bobbin winder pulley rotates in the direction indicated by an arrow in Fig. 5.

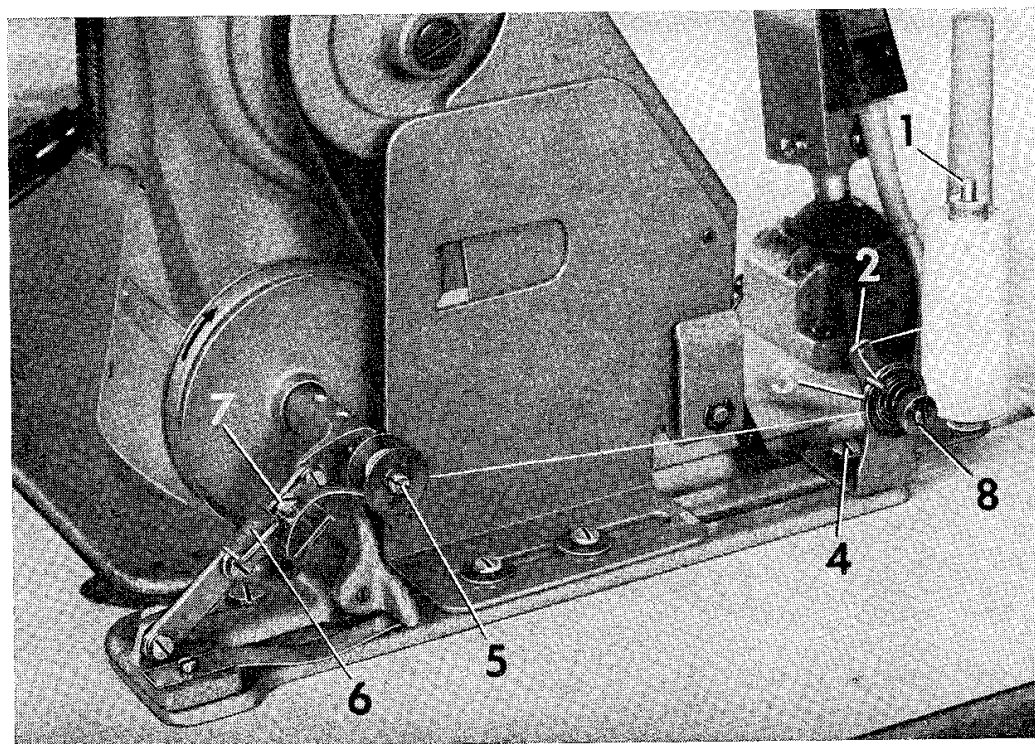

R 11369

Fig. 5

5. Changing the bobbin and threading the bobbin case

Raise the needle to its highest position and open the bed slide. With the thumb of your right hand open latch **B** (Fig. 6), then push the thumb nail under the projecting flange **C** of the bobbin case cap and lift the latter out of the machine with thumb and fore-finger. The bobbin is exposed in the bobbin case base and can be taken out easily.

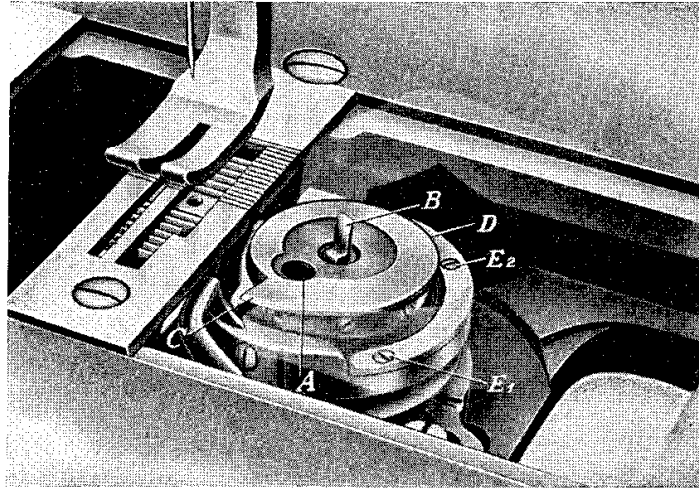

Fig. 6

Place a full bobbin in the bobbin case cap so that the thread draws on top from left toward the right, as shown in Fig. 7.

Hold the bobbin steady in the bobbin case, pull the thread into slot **X** and draw it under tension spring **Y**. Leave a loose end of thread about 7 mm long outside the bobbin case. Place the bobbin case with the bobbin on the center stud in the bobbin case base and close latch **B** (Fig. 6) as well as the bed slide.

Note that the rotary hook of Pfaff machines 151 and 153 is located on the left of the needle plate.

R 9931

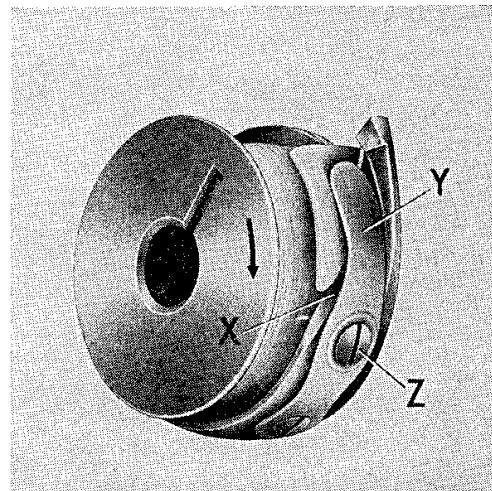

Fig. 7

6. Selecting the correct needle

To ensure reliable stitch formation, check to see that the correct needle is inserted in the machine.

Needle systems

The following needle systems are used for the individual machine classes:

134 for Pfaff machines 141, 142, 143, 144, 151, 541, 542, 543 and 544

(in some cases also **34** for Pfaff machines 142 and 144)

134–35 for Pfaff machines 142-732/09; 142-732/11; 145 H3; 146 H3; 545 H3; 546 H3 and 555 H3

134 FLG for Pfaff machines 142-720/02-6/01 and 144-720/02 in needle gauges from 1.6 to 2.2 mm inclusive. (See also Additional Instructions for Pfaff machines 142-720/02 to 594-720/02)

134 KK for the Pfaff 153.











134 RER and **134 REL** for the Pfaff 546 H2.

190 for the Pfaff 543-712/ . . . , 545 H4, 546 H4 and 555 H4.

Needle point styles

These needles are available with different type points to suit different requirements. The various needle point styles are identified by a letter following the needle system, e. g. **134 R**.

Fabrics are stitched with a round-point needle, identified by **R**, while for leather work needles are available with the following styles of point:

LR		Narrow reverse twist point
LL		Narrow twist point
LACK		Patent leather point
P		Extra-narrow wedge point
PCR		Extra-narrow wedge point with right-twist groove
PCL		Extra-narrow wedge point with left-twist groove
S		Narrow cross point; for long, straight stitches
D		Triangular point; for short, straight stitches
VR		Reverse twist spear point
VL		Twist spear point

Rubberized fabrics and plastic materials are sewn with round-point needles.

Needle and thread sizes

The choice of the correct needle is not only dependent on the specified needle system and the corresponding needle point, but also on the machine model (A, B, C and D) and fabric and thread weights (see chart on next page).

The needle size (Nm) is indicated on the shank in hundredths of a millimeter. This means, for example, that a needle of size 100 has a shank diameter of $100/100 = 1$ mm.

Model	Needle size (Nm)	Cotton	Silk	Synthetic	Linen
A	60	100–80	140	200–150	
	70	70–60	120	150–120	
B	80	60–50	100	120–100	
	90	50–40	80	100– 80	70
	100	40–30	70	80–60	60
C	110	30–24	60	60–50	50
	120	20	50	50–40	40
	130	12	40	40–30	35
	140	10	30	30–20	30
D	150	8	25	20–18	25
	160	6	20	18–15	20
	170	6-ply fancy-effect thread	10	15–10	20
	180	9-ply fancy-effect thread	10	0.6 mm dia.	18

The thread sizes listed below are still reliably trimmed by the subcl. -900/.. thread trimmers fitted to 540 series machines.

Subclass	Maximum thread size	
	Cotton	Synthetic
-900/16 or /56	12/3	20/3
-900/16 or /56-966/05	12-ply fancy-effect thread	11/4

7. Changing the needle

Raise the needle bar to its highest point, loosen the needle set screw half a turn, and pull the damaged needle out of the needle clamp.

Insert a new needle into the clamp, making sure that its short groove faces toward the sewing hook. Push the needle up as far as it will go and tighten the needle set screw securely.

Never use rusty needles.

8. Threading the needle

Pass the thread from spool **1** (Fig. 8) through the holes in stud **2** and thread guide **3**, around thread retainer **4**, clockwise around and between tension discs **5**, under thread controller disc **6**, through thread check spring **7**, up and through thread guide **8**, from right to left through the hole in take-up lever **9**, then down and through thread guides **10**, **11** and **12**, and from left to right through the needle.

The spool holder on top of the machine arm will be supplied on special request only because the thread stand which is supplied with the machine regularly ensures a smoother passage of the thread to the needle.

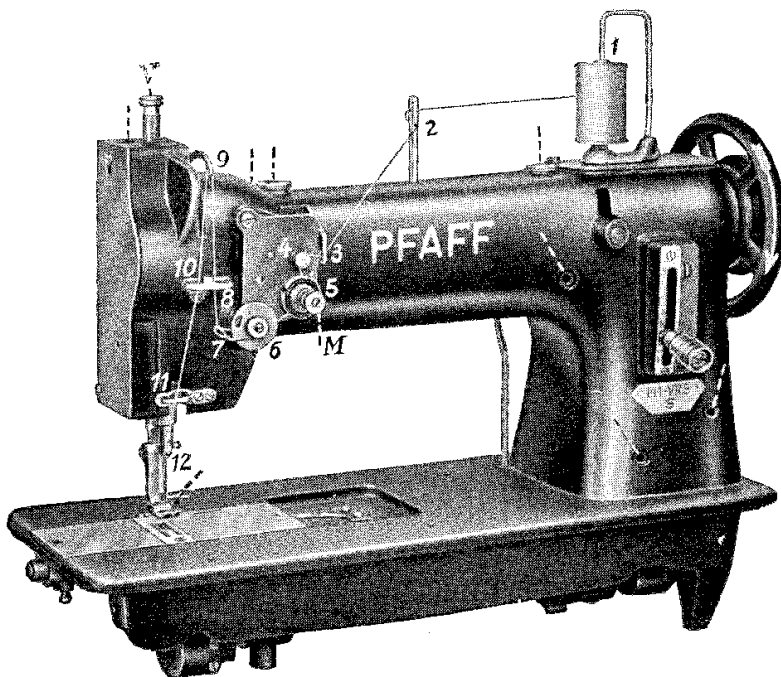

Fig. 8

9. Drawing up the bobbin thread

Hold the end of the needle thread and turn the balance wheel toward you, as indicated by an arrow in Fig. 8, until the needle moves down and up again. As the needle moves up, it catches the bobbin thread which comes up with it through the needle hole. Lay both threads back under the presser foot, place the material in the machine and lower the presser foot. Hold the ends of both threads until the machine has made a few stitches.

10. Regulating the thread tension

Adjusting the upper tension

Turn tension nut **M** (Fig. 8) clockwise for more tension, or counter-clockwise for less tension.

If the upper tension is too loose, the bobbin thread will draw the needle thread down so that it forms small kinks on the underside of the material, as shown in Fig. 9.

If the upper tension is too tight, the bobbin thread will be pulled up (Fig. 10) or the needle thread will break.

Both tensions are correctly balanced, if the needle and bobbin threads interlock in the center of the material, as shown in Fig. 11.

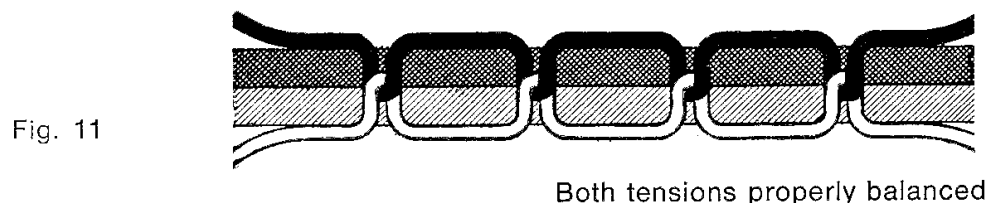
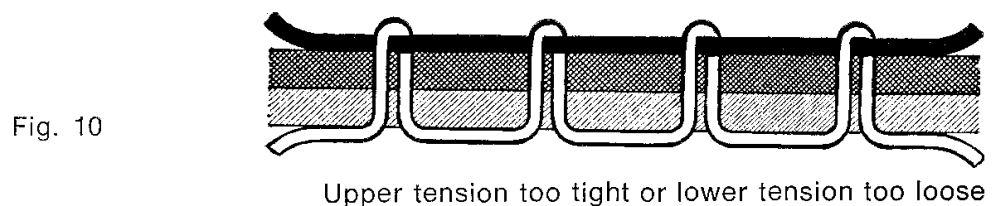
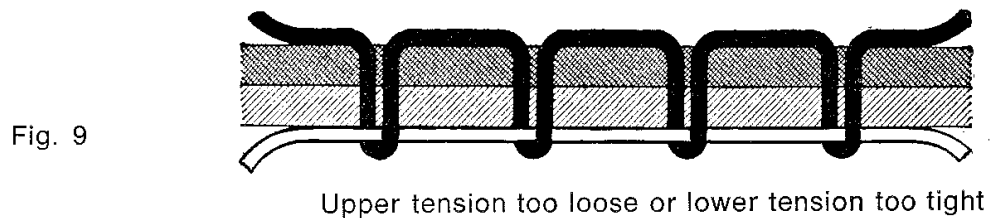

When you raise the presser bar, the upper tension is released automatically so that the work can be easily removed from the machine. To do this, pull the work back (in forward feeding direction), never forward as this may cause bending of the needle, skipping of stitches or thread breaking.

Adjusting the lower tension

Take the bobbin case out of the machine and regulate the tension by turning screw **Z** (Fig. 7) with the hook screwdriver, as appropriate. Turn this screw clockwise for a tighter tension, or counter-clockwise for a looser tension.

The tension is correct if a noticeable resistance of spring **Y** (Fig. 7) has to be overcome when pulling the thread out of the bobbin case.

If puckering occurs on delicate materials although the tension has been set correctly, ease both tensions slightly.

11. Regulating the stitch length

The stitch length is regulated by turning thumb nut **S** (Fig. 12) on the feed regulator lever.

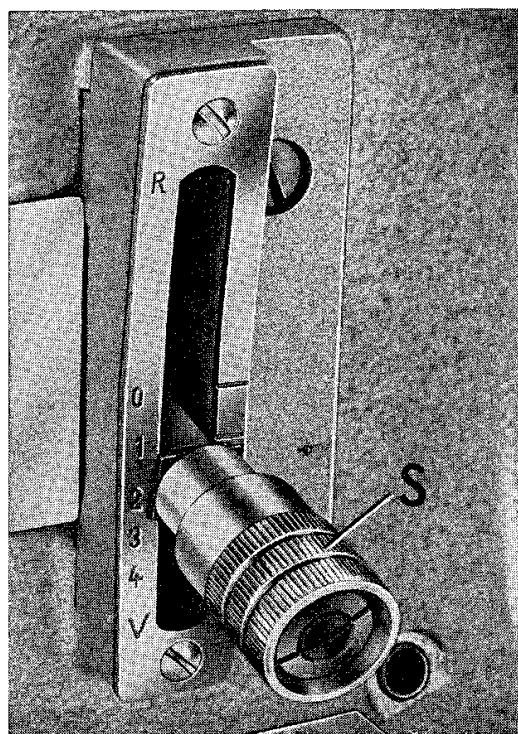

R 9933

Fig. 12

Turn this nut clockwise for shorter stitches, or counter-clockwise for longer stitches. The numerals on the left of the scale indicate the stitch length in millimeters. The letters **V** and **R** on the left side of the scale (Fig. 12) stand for forward and backward sewing, respectively.

All machines with the exception of the Pfaff 141-705/03 and 143-705/03 are fitted with a spring-return feed regulator as standard. This device incorporates a spring which permanently holds the feed regulator lever down in forward feeding position. When the lever is pushed up as far as it will go, the machine will sew in reverse. And conversely, when the lever is released, forward sewing will be resumed instantly.

If desired, the machine can be fitted with a pedal which makes it possible to reverse the direction of feed by foot action.

12. Regulating the pressure on the material

The amount of pressure to be exerted by the presser foot must be adapted to the material to be sewn. The pressure is set correctly if the material is advanced through the machine evenly without being injured by the teeth of the feed dog.

The pressure on the material is regulated by turning screw **V** (Figs. 8 and 24). Turn this screw in for more pressure, or out for less pressure.

On machines equipped with one or two leaf springs on the machine arm instead of the conventional presser bar spring with pressure regulating screw, the presser foot pressure is increased by turning knurled nut **V** (Fig. 13) upwards, and decreased by turning it downwards.

R 7769

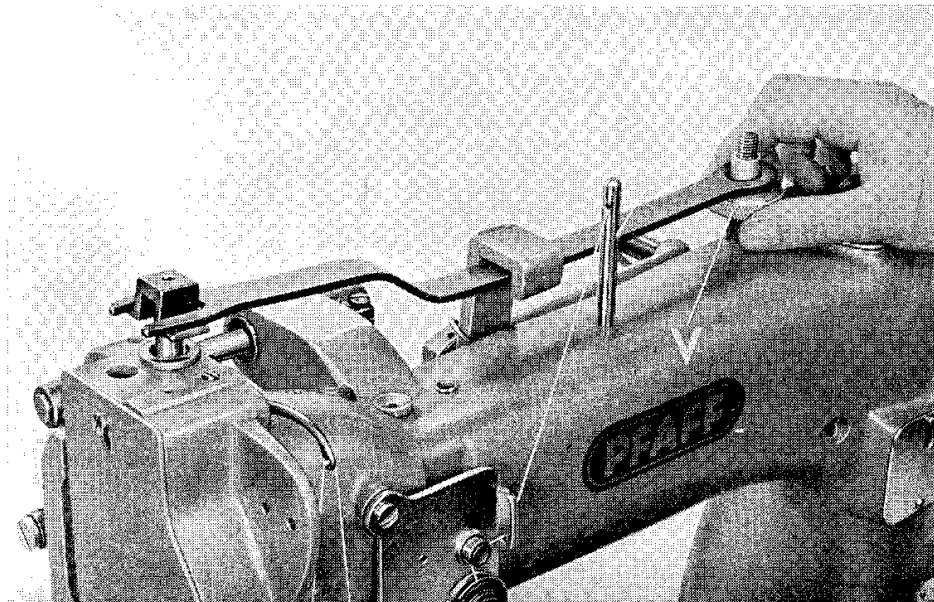

Fig. 13

13. Cleaning the sewing hook

The sewing hook is the most essential part of the whole machine and, for this reason, should be cleaned thoroughly from time to time. To do this, raise the needle bar to its highest point, open the bed slide and remove the bobbin case with the bobbin. Take out the three screws **E₁**, **E₂** (Fig. 6) and **E₃** (not visible in ill.) and remove the hook gib. Turn the balance wheel until point **S** of the bobbin case base is about to enter groove **N** of the hook (Fig. 14). When in this position, the bobbin case base can be tipped out easily by holding center stud **Z** with thumb and forefinger while turning the balance wheel back and forth lightly.

Clean hook and hook raceway thoroughly with kerosene. If the cotton wool in slot **O** (Fig. 14) should have become matted, it should be replaced and the new cotton wool be soaked with oil.

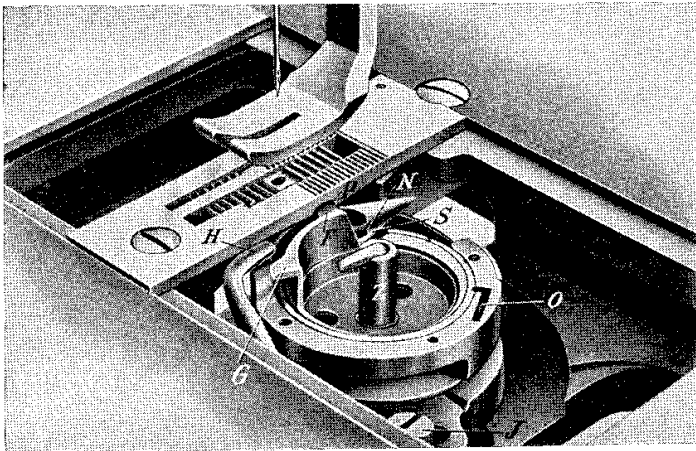

Fig. 14

To clean the parts in the vicinity of the sewing hook, take out set screw **20** (Fig. 4) and pull the hook up out of the machine. When the hook is replaced, pin **19** (Fig. 4) ensures proper positioning and eliminates the need of retiming the hook.

In replacing the bobbin case base, make sure that position finger **F** (Fig. 14) enters slot **P** on the underside of the needle plate. Replace hook gib and tighten screws **E₁**, **E₂** and **E₃**. Put a drop of oil into the hook raceway, replace the bobbin case with the bobbin and close latch **B** (Fig. 6).

Never run the machine with the needle plate removed as this may result in damage to the bobbin case or the bobbin case opener.

The above instructions also apply to all two-needle sewing machines covered by this Instruction Book.

14. The safety clutch

Model C and D machines are equipped with a safety clutch which prevents disturbance of the hook timing and damage to bobbin case base in case of thread jamming in the hook raceway.

If an irregularly spun needle thread should jam in the hook raceway and block the sewing hook, the safety clutch automatically disengages the hook drive.

After the jammed thread has been removed, tilt back the sewing head and rotate the balance wheel, while holding the hook drive shaft steady, until the tip of the latch is positioned exactly above the groove in the clutch bushing. Now push back the spring-loaded pin so that the latch can snap into this groove.

To resume sewing, simply let down the sewing head again.

R 9343

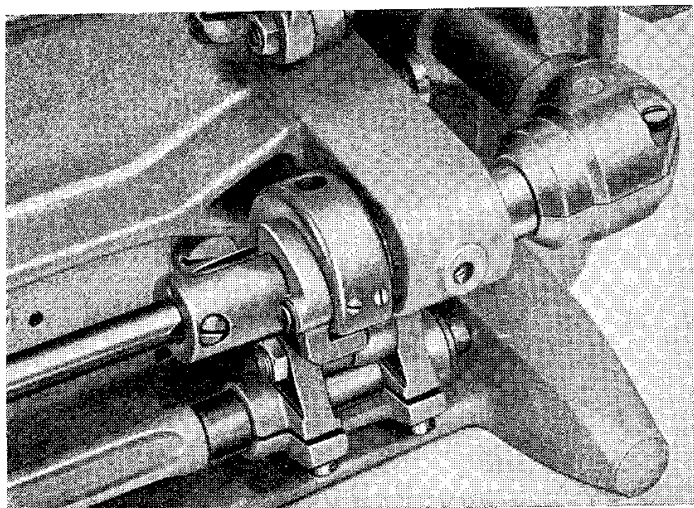

Fig. 15

Additional instructions

for Pfaff machines 141-705/03 and 141-705/03-725/01

The Pfaff 141-705/03 and 141-705/03-725/01 have the same feed regulator. This new mechanism makes it possible to select the required stitch length from the twelve different ones available. These twelve stitch lengths are divided into four stitch length groups (I–IV) having three predetermined stitch lengths each (Fig. 16).

The following table lists the stitch lengths in millimeters as well as the number of stitches per inch.

For adjustment, as well as engagement and disengagement of the trimming mechanism on the Pfaff 141-705/03-725/01, see pages 19 and 20.

Stitch length group	I	II	III	IV
Stitches per inch	33 28 25½	23 21 19	17 15 13	12 11 9½
Stitch length in mm	0.8 0.9 1.0	1.1 1.2 1.3	1.5 1.7 1.9	2.1 2.3 2.6
Stitches per cm	12½ 11 10	9 8 7½	6½ 5½ 5	4½ 4 3½

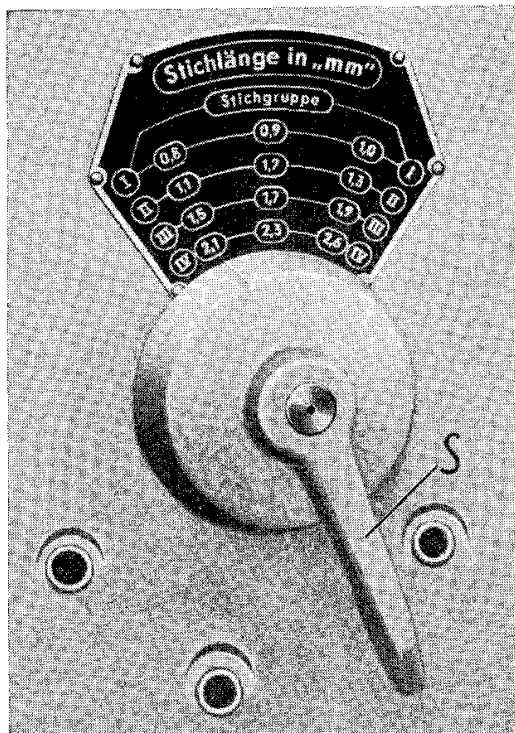

R 6575

Fig. 16

15. Regulating the stitch length on Pfaff machines 141-705/03 and 141-705/03-725/01

The stitch length is regulated as follows:

Begin by selecting the required stitch length group from the table on p. 16 and interchange the feed gears as indicated in the feed gear housing (Fig. 18).

Press down button **K** (Fig. 17) and turn the balance wheel until the button snaps in position.

Again rotate the balance wheel backwards or forwards until notch **M** (Fig. 17) on the balance wheel is opposite the number of the stitch length group chosen (I, II, III or IV). Release button **K** and turn feed regulator lever **S** (Fig. 16) to the desired stitch length.

R 8994

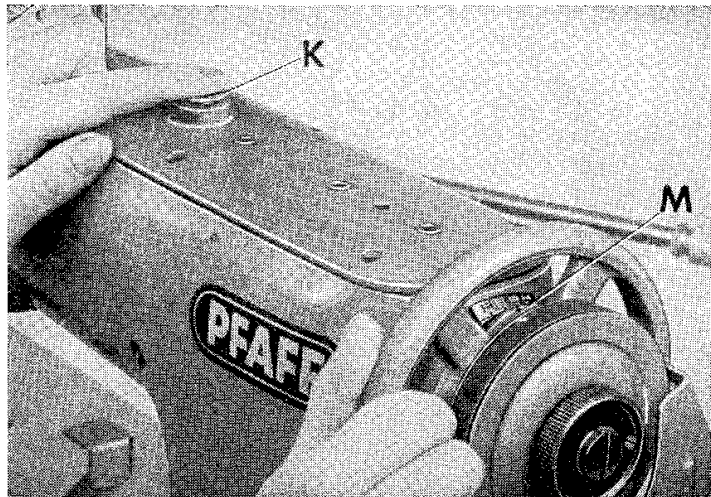

Fig. 17

16. Changing the feed gears on Pfaff machines 141-705/03 and 141-705/03-725/01

Exchanging the feed gears is greatly facilitated by wheel puller which is supplied with the machine. To pull the feed gear off its shaft, slip the fork of the wheel puller under the projecting rim of the hub and pull (Fig. 18).

Consult the diagram on the feed gear housing (Fig. 18) to see how the feed gears have to be exchanged to obtain the stitch length group and stitch length desired. Exchange the feed gears accordingly.

For better identification, the outside of the feed gears and the corresponding symbols used in the diagram are painted yellow, green, red and blue. In slipping the feed gear onto its shaft, see that the key on the shaft enters the notch in the feed gear and that the mating gears are meshed properly.

For instructions on how to adjust the trimmer of the Pfaff 141-705/03-725/01, please refer to Chapters 17 and 18.

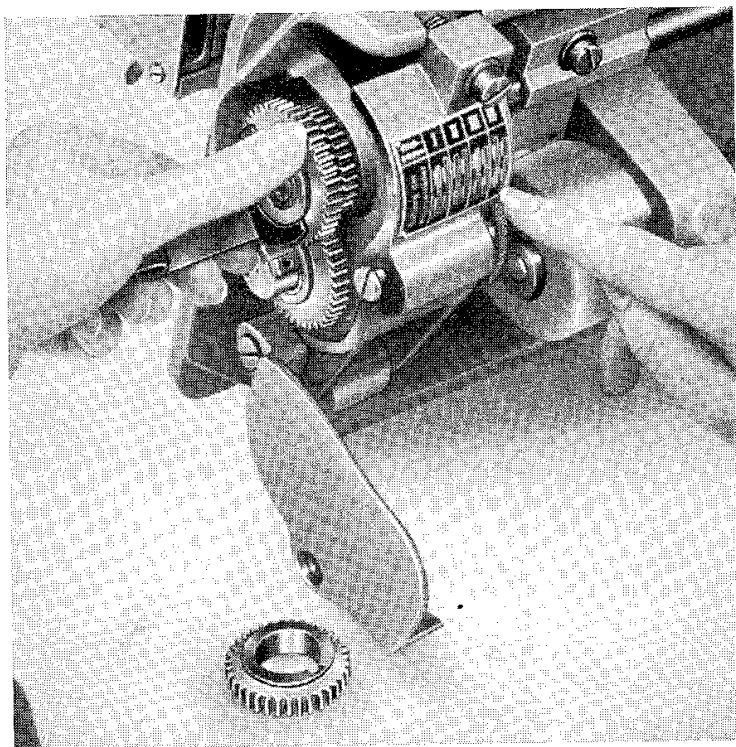

R 6585

Fig. 18

17. Adjusting the trimmer on Pfaff machines 141-705/03-725/01

To take out the trimming knife for sharpening, loosen set screw **C** (Fig. 19) swing the knife halfway between its operative and inoperative positions and pull the knife out of its guide. As you replace the knife, make sure its cutting edge bears lightly against the edge of the needle plate slot which serves as a guide. However, the knife must never be set too close to this edge as this might cause the knife to jam as it is thrown out of action. When the setting is correct, tighten set screw **C** securely.

The cutting stroke of the knife should be exactly halved by the needle hole. To adjust the position of the cutting edge in relation to the needle hole, loosen nut **M** (Fig. 19) and move the knife carrier forward or backward, as appropriate. This setting also applies to knives which have been resharpened repeatedly. After the adjustment, tighten nut **M** securely.

The vertical position of the knife is adjusted by screw **S** (Fig. 19). Turn this screw clockwise to set the knife lower, or counter-clockwise to set it higher. The knife is set correctly, if its cutting edge is positioned just above the bottom of the needle plate guide.

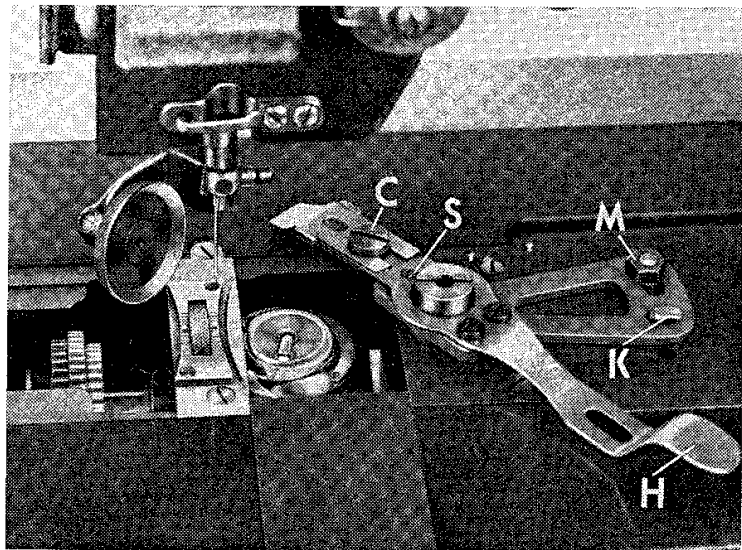

Fig. 19

It goes without saying that only a sharp and correctly set knife will produce a clean cut.

Blunt knives are either sharpened with a triangular oilstone by hand (Fig. 20) or with the aid of a knife sharpener. When sharpening the knife, take care that the cutting angle is preserved and that the cutting edge is sharpened thoroughly up to its innermost corner **e** which has to take most of the strain.

18. Operating the trimmer

To engage the trimmer, turn lever **H** (Fig. 19) to the right until it catches on lug **K** on the knife carrier. To disengage it, lift lever **H** up slightly and swing it forward.

With the trimmer thrown out of action, the machine can be used for ordinary sewing operations.

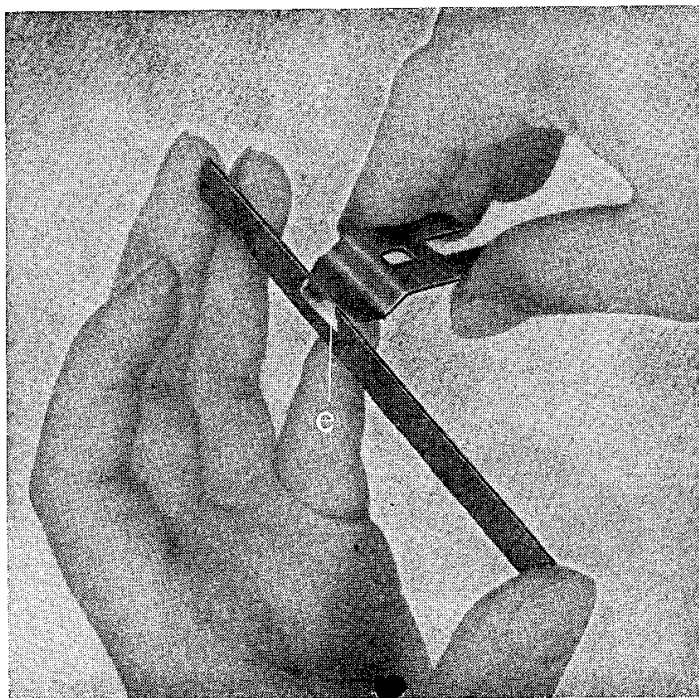

R 5436

Fig. 20

Additional instructions

for Pfaff machines 143-705/03

The general instructions given for the Pfaff 143 apply also to the Pfaff 143-705/03 wheel-feed machine. In addition, however, the following instructions should be heeded:

19. Regulating the stitch length on Pfaff machines 143-705/03

On wheel-feed machines the stitch length is regulated under the bedplate instead of on the machine arm, as is customary. The feed gear assembly (Fig. 21) enables selection of three pre-determined stitch lengths.

To change the stitch length, pull out pin **P** (Fig. 21) and move lever **H** to position **a**, **b** or **c**, as desired, while turning the balance wheel. Let pin **P** snap into position.

To convert the machine to another stitch length group, consult the Spare Parts Catalogue which contains a list of all feed gears available for this machine.

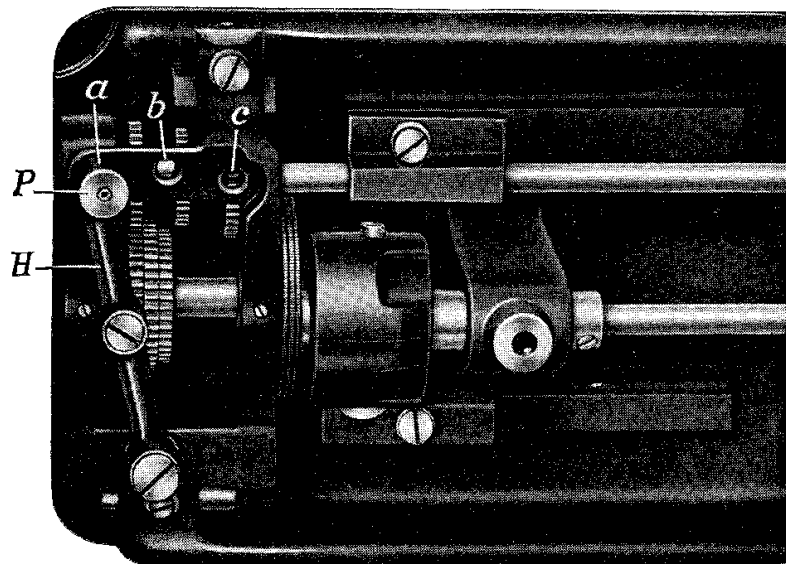

Fig. 21

Additional instructions

for Pfaff machines 145, 545 and 555

Pfaff machines 145 and 545 are fitted not only with compound feed like the Pfaff 141 or 541, but also with alternating pressers which makes them unison-feed machines capable of feeding materials that are difficult to handle.

Apart from the general instructions which apply to Pfaff machines 145 and 545 also, the following special instructions should be heeded:

20. Exchanging the alternating pressers

Raise presser bar lifter **a** (Fig. 22) and rotate the balance wheel to bring the needle to its highest point. Loosen screw **b** and pull out the vibrating presser, rotating it slightly to the right and left.

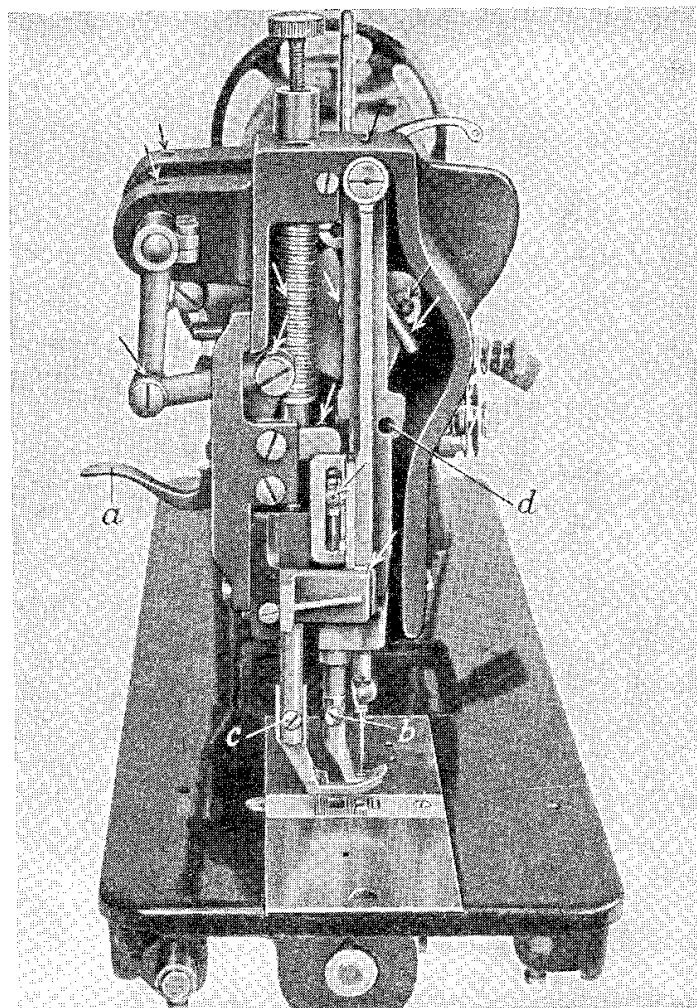

R 3503

Fig. 22

When replacing the vibrating presser make sure you push it up as far as it will go and position it so that the needle is centered in its needle hole. Then tighten screw **b** (Fig. 22) securely.

The lifting presser can be removed only when the presser bar is raised. To do this, take out screw **c** (Fig. 22) and pull out the lifting presser, tilting it back and forth slightly.

When replacing the lifting presser, push it up as far as it will go so that screw **c** can be pushed through the hole in its shank and tightened securely.

R 6189

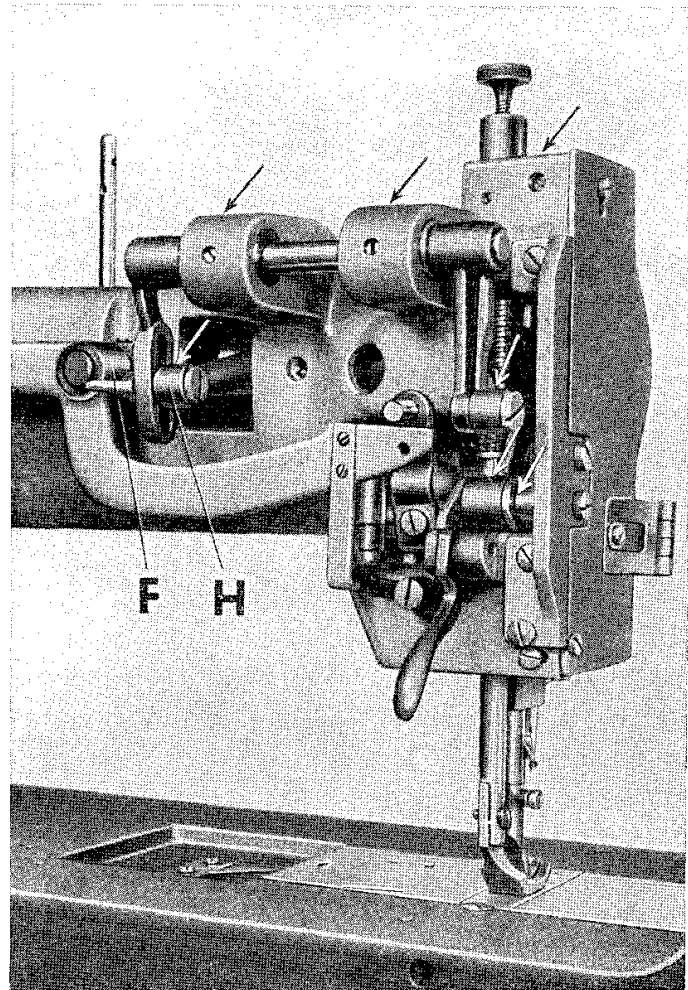

Fig. 23

21. Lubricating the machine

Since Pfaff machines 145 and 545 are fitted with alternating pressers, they have a number of additional oiling points which are marked by arrows in Figs. 22 and 23. Of these, particularly the points of friction at the needle-bar-end of the machine, such as the needle bar (inside needle bar frame in Fig. 22) and the sleeve take-up with its round shank (behind needle bar in Fig. 22), require thorough and regular lubrication.

All moving and rotating parts should be oiled regularly. To prevent soiling of the work through dripping oil, sew a few seams on a piece of scrap material to absorb all excess oil.

Never try to remedy certain faults by applying excessive quantities of oil. Excessive oiling will merely soil the work. Therefore, oil the machine sparingly, but regularly.

22. Setting the foot lift

To adapt the foot lift to the thickness of the material to be sewn, loosen wing nut **F** (Fig. 23) and adjust the position of lifting eccentric connection **H** in the slot of the lifting crank.

Move the connection upwards for a higher foot lift, or downwards for a lower foot lift.

Additional instructions

for Pfaff machines 142, 144, 146, 542, 544, 546, 542-748/01 and 546-748/01

23. Threading the needles

To thread the left needle, pass the thread from the spool on the thread stand through the two upper holes in stud **1** on the machine arm (not shown in Fig. 24), through thread guide **2**, around thread retainer **3**, around and between tension discs **4**, down and around thread controller disc **5**, through thread check spring **6**, up and through thread guide **7**, from right to left through the hole in take-up lever **8**, down and through thread guides **9**, **10** and **11**, and from right to left through the eye of the left needle **12**.

To thread the right needle, pass the thread from the second spool on the thread stand through the two lower holes in stud **1** (not shown in Fig. 24), thence to **2**, **14**, **15**, **5**, **6**, **7**, **8**, **9**, **10** and **16**, and from left to right through the eye of the right needle **17**.

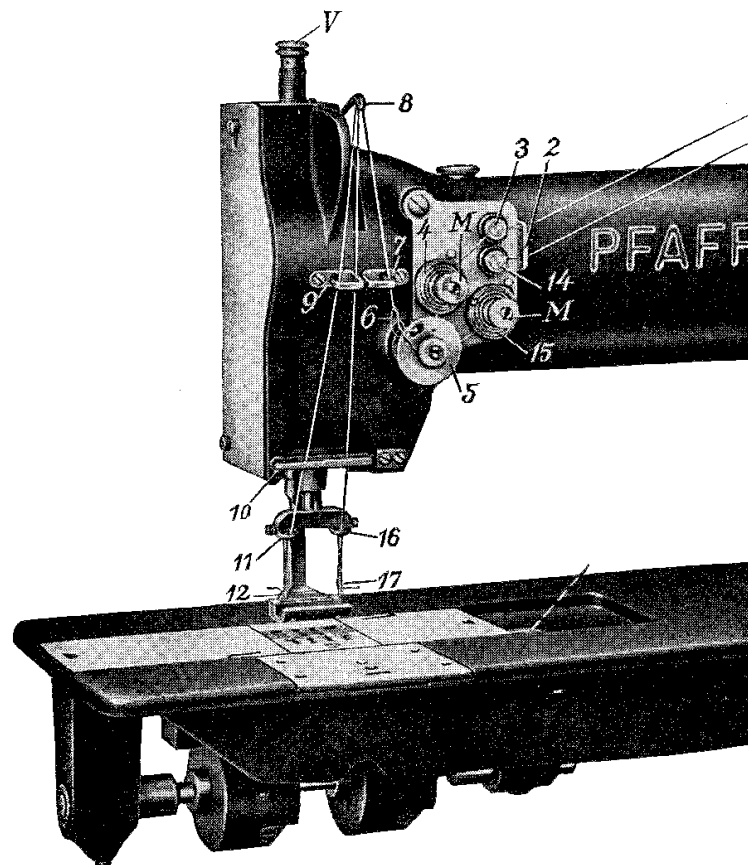

Fig. 24

24. Adjusting the puller feed of the Pfaff 542-748/01

The Pfaff 542-748/01 is equipped with an additional puller feed which is arranged at the back of the presser foot and, acting in synchronization with the drop feed, ensures even feeding of the material. The lower feed roller is positively driven by the feed rock shaft via a connecting link.

When the presser bar lifter is lowered, the upper feed roller is lowered onto the lower feed roller and the material is firmly gripped between them. To increase the rate of feed of the puller feed for sewing materials that are difficult to handle, loosen the hexagon nut and adjust the position of the connection in the elongated hole of lever **X** (Fig. 25). Then tighten the hexagon nut securely again. As a result of this adjustment, a stronger pull is exerted on the material behind the presser foot.

To remove the work, the top feed roller is raised by pushing up the lifting lever.

Operation and maintenance of this machine is governed by the general instructions given in this book, except that the additional oiling points shown in Fig. 25 should be supplied with oil.

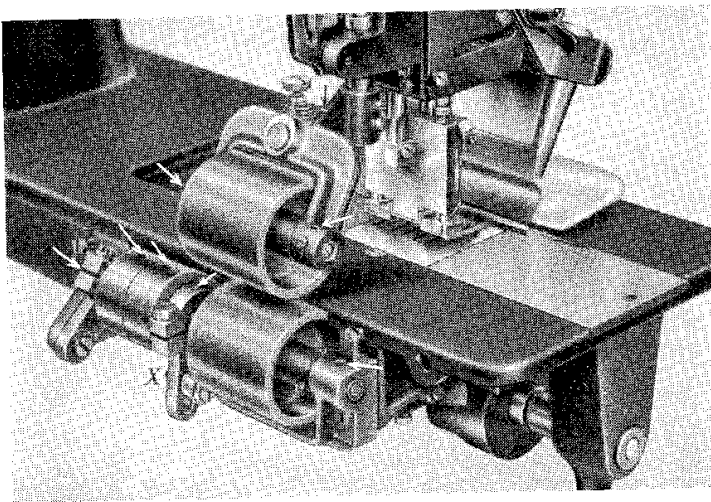

Fig 25

Additional instructions

for Pfaff machines 543-712/01 and 543-712/02

The Pfaff 543-712/02 is a single-needle sewing machine equipped with a two-speed Stop-motor and a roller thread tension, while the Pfaff 543-712/01 is fitted with a standard motor and a disc-type thread tension. Both these machines are equipped with an extra-large vertical rotary hook.

Other than that, the mechanical setup of the Pfaff 543-712/.. is identical with that of the Pfaff 143 flatbed sewing machine so that all operating and servicing instructions given for the latter also apply to the former, the only exception being Chapters 8 and 11.

25. Threading the needle of the Pfaff 543-712/..

Fig. 26

R 9697 a

Pass the thread from the spool up and over the thread guide at the top of the thread stand, down and through the hole of the angular thread guide on the machine arm, and through the thread retainer, making sure that the thread enters the slot in the thread retainer stud. Now lead it clockwise around the roller tension of subcl. -712/02 machines or the disc-type tension of subcl. 712/01 machines. Then pass it around the thread controller disc, through the thread check spring, up and through the thread guide, from right to left through the eye in the take-up lever, down and through both thread guides, and from left to right through the needle eye.

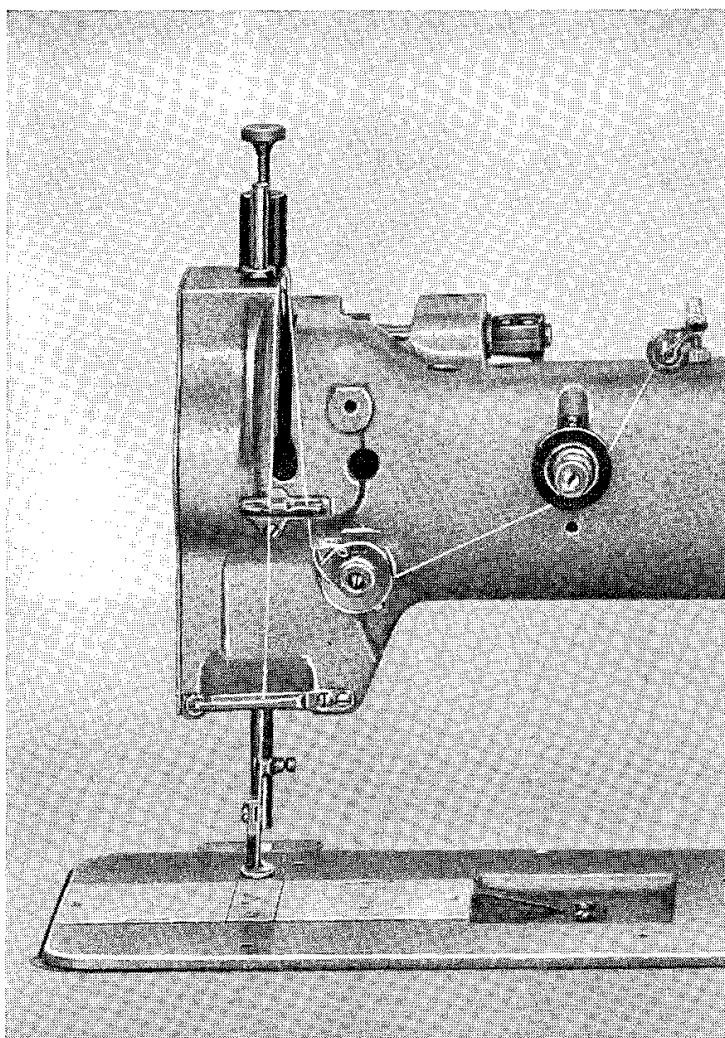

Additional instructions

for Pfaff machines 546-748/01

The Pfaff 546-748/01 is a two-needle, flatbed sewing machine fitted with unison feed, two extra-large vertical rotary hooks and additional puller feed which ensures smooth feeding of "problem" materials.

Fitted with a subcl. -368/01, -369/01 or -371/01 attachment this machine is primarily intended for attaching waistbands to trousers and skirts.

Other than that, the Pfaff 546-748/01 is identical with our standard two-needle, flatbed sewing machine so that the general operating and servicing instructions given for this machine apply to them also. The only exceptions are the instructions for setting the foot lift and adjusting the puller feed which are given below.

Fig. 27

R 9680

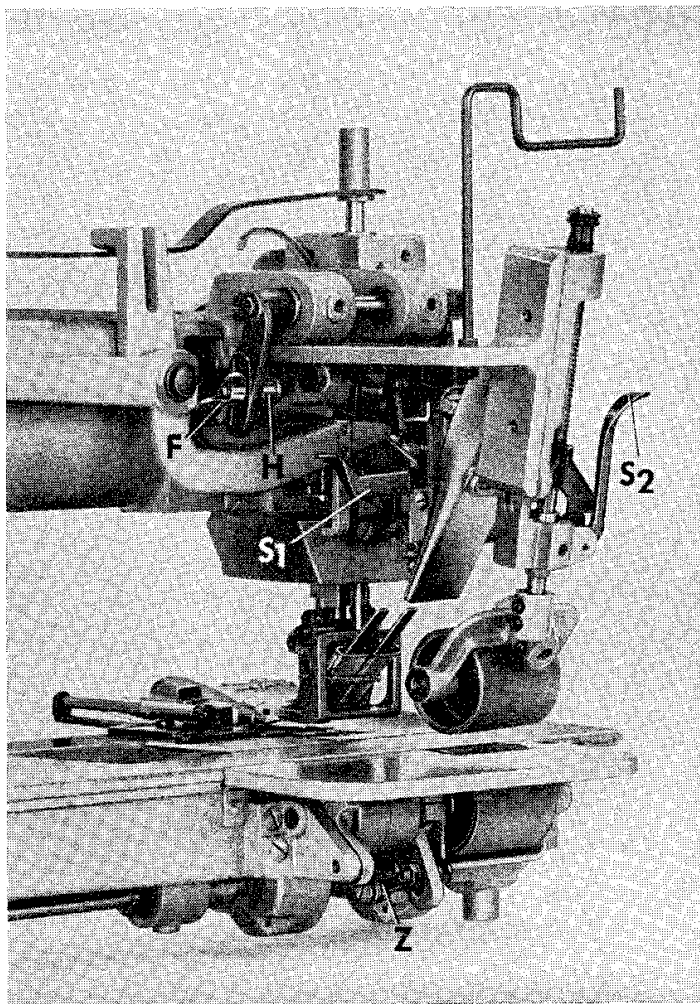

26. Setting the foot lift

To adapt the foot lift to the thickness of the material to be sewn, loosen wing nut **F** (Fig. 27) and adjust the position of lifting eccentric connection **H** in the slot of the lifting crank. Move the connection **H** in the slot of the foot lift, or downward for a lower foot lift. Then tighten wing nut **F** securely.

If delicate fabrics should continue to pucker when sewn on a subcl. -368/01, -369/01 or -371/01 machine, although the foot lift was adjusted to replace the rear swing-away folder by one having a built-in retaining mechanism and a regulating screw (**R** in Fig. 28).

To increase the pressure exerted on the fabric by the re-

taining tongue, turn screw **R** backward; to decrease the pressure, turn it forwards.

For easy removal of the material, press against the knee lever to raise the vibrating and lifting pressers and lock the latter in position by lever **S₁** (Fig. 27).

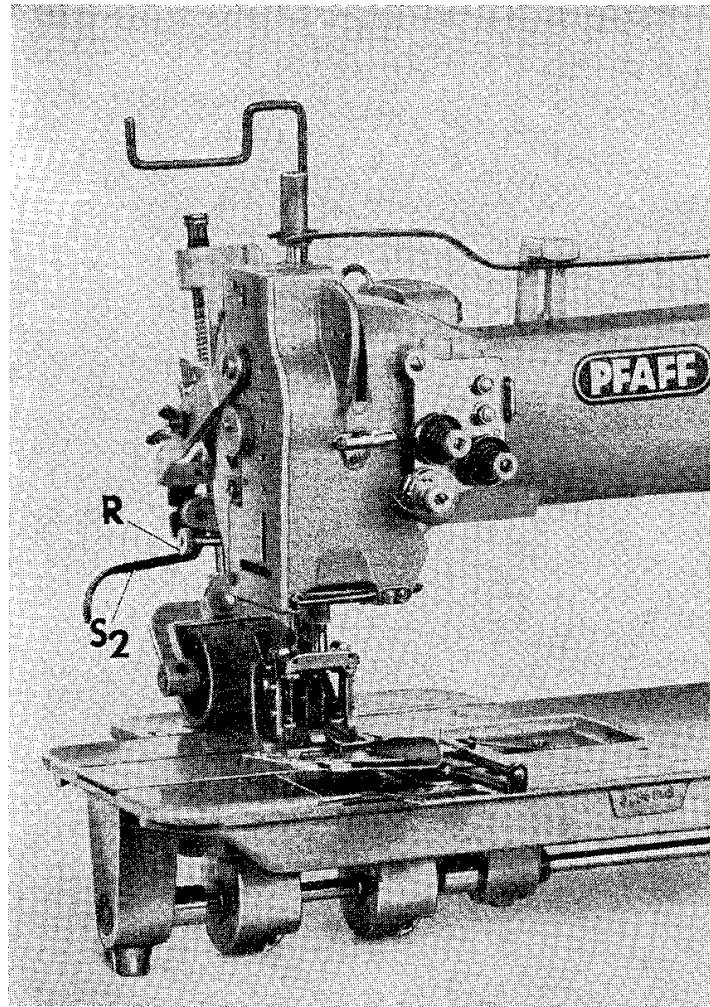

Fig. 28

R 9679

27. Adjusting the puller feed

The Pfaff 546-748/01 is equipped with an additional puller feed which is arranged behind the presser foot and, acting in synchronization with the unison feed, ensures even feeding of the material. The lower feed roller is positively driven by the feed rock shaft via a connection and has a built-in retaining mechanism.

By lowering presser bar lifter **S₂** (Fig. 27), the upper feed roller is lowered onto the lower feed roller and both advance the material together. To increase the rate of feed of the puller feed so that it exerts a stronger pull on the material at the back of the needles, adjust the position of connection **Z** (Fig. 27) in relation to the feed lever. Then tighten the hexagon nut securely.

Additional instructions

for Pfaff machines fitted with thread puller/trimmer -900/... , automatic presser foot lifter -910/.. and reverse-sewing mechanism -911/..

Since these machines are equipped with Stop motor and electro-magnetic thread puller/trimmer, manual needle positioning and thread trimming are completely eliminated.

28. Pedal operation

When you depress the heel of the pedal at the completion of the sewing action, the needle is raised automatically, the needle thread is pulled to the underside of the material and both threads are trimmed. All you have to do to remove the work is raise the presser foot (this takes place automatically on machines with subcl. -910/..). The thread ends remaining on the underside of the material are long enough to permit them to be pasted down reliably.

The pedal of these machines controls the following functions:

1. When you depress the tip of the pedal, the machine starts sewing. The harder you press, the faster the machine will run. (If it is fitted with an inching device, the pedal will also control slow stitch-by-stitch sewing.)
2. When you relieve the pressure and allow the pedal to return to its neutral position, the needle is lowered for turning corners.
3. When you depress the heel of the pedal, the needle is raised to its highest point, the needle thread is pulled to the underside of the material, and both threads are trimmed. (On subcl. -910/.. : presser foot is raised.)
4. When the pedal is returned to its neutral position again, the needle remains at its highest point.

The various pedal positions are shown below:

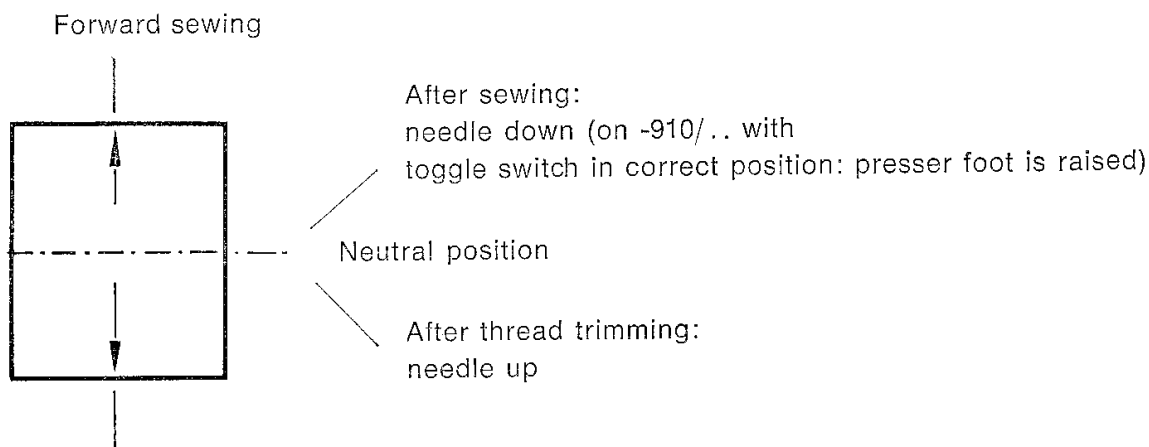

Raising needle and
trimming threads (on subcl. -910/.. : presser foot is raised)

If the machine is fitted with two pedals (subcl. -911/01), it will sew in reverse when both pedals are simultaneously pressed forward. On machines with subclass -911/03 or -911/05 the feed is reversed by means of a hand switch at the needle-bar end of the machine.

Guards

Finger guard (Fig. 29)

All machines are fitted as standard with a guard which protects the operator's fingers against injury by the needle.

The design of the finger guard and the method of fitting it depend on the machine version.

Please make sure that this guard is always fitted correctly.

R 11466

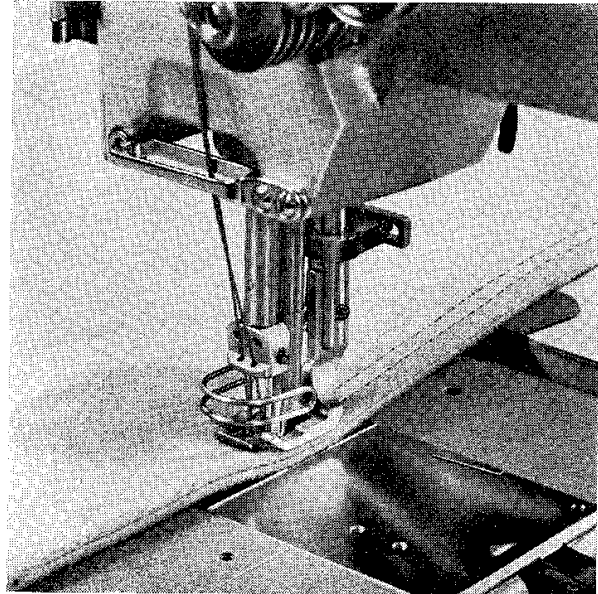

Fig. 29

Take-up lever guard (Fig. 30)

All machines are normally equipped with a take-up lever guard which conforms to the safety regulations. It is imperative that this safety device is fitted at all times.

R 7111

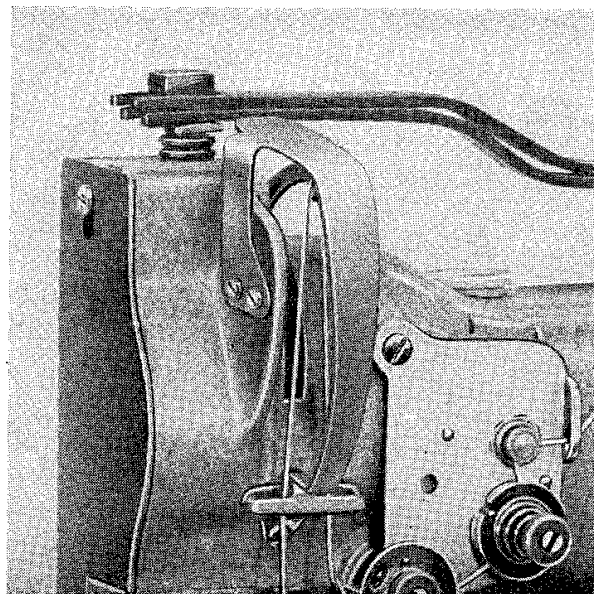

Fig. 30

Belt guard on balance wheel (Fig. 31)

This guard covers the point where the belt runs onto the balance wheel.

The belt guard is mounted as follows:

Guard **1** is secured with two screws **2** and positioned so that it covers the point of belt entrance completely.

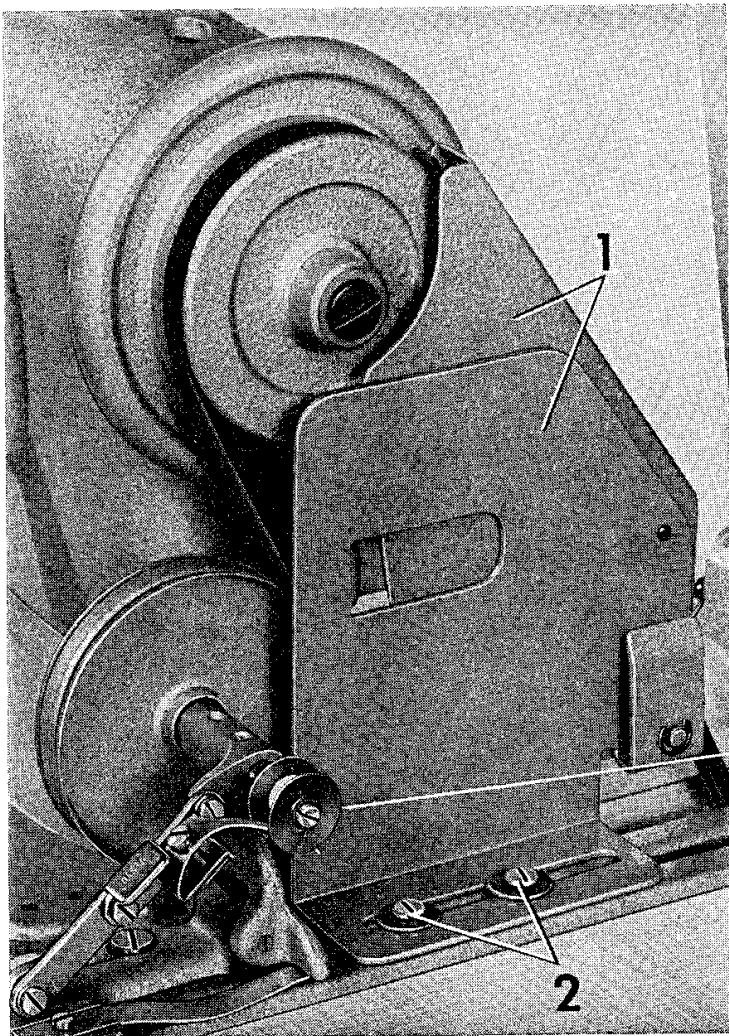

R 11369A

Fig. 31

Belt guard below tabletop (Fig. 32)

This guard covers the belt below the tabletop.

Loosen wing nut **4**, and position guard **5** so that motor pulley and V-belt run freely in the guard.

R 10865

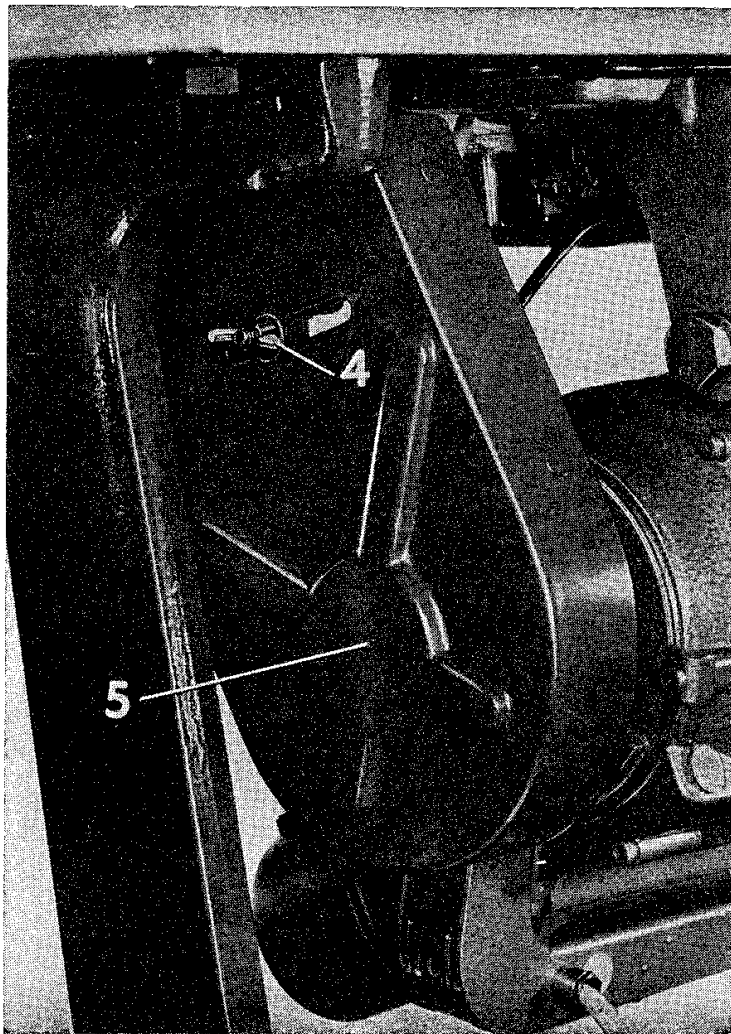

Fig. 32

Trouble shooting

Machine skips stitches

Cause

Wrong needle system.
Needle bent.
Needle inserted incorrectly.

Incorrect threading.

Remedy

For correct needle system see Chapter 6.
Insert new needle as instructed in Chapter 7.
Position needle so that its short groove faces toward the sewing hook.
Thread needle as instructed in Chapters 5, 8, 23 and 25.

Thread breaks

Cause

For any of the reasons indicated above.
Thread tensions too tight.
Knotty thread.
Needle point blunt or damaged.
Thread snarled up.

Remedy

See remedies listed above.
Regulate tensions as instructed in Chapter 10.
Use high-quality thread only.
Replace needle.
Check upper threading from spool of thread to needle.

Faulty stitch formation

Cause

Improper tension.
Wrong needle size and/or thread used.
Pieces of thread between tension discs or under bobbin case tension spring.

Remedy

Regulate tensions as instructed in Chapter 10.
See Chapter 6.
Remove thread and re-adjust tension as instructed in Chapter 10.

Needle breaks

Cause

Wrong needle system.

Needle bent.
Needle too thin.

Remedy

Insert needle of correct system as instructed in Chapter 6.
Insert new needle
Insert thicker needle.

Machine binds

Cause

Lack of oil.

Wrong lubricant.

Hook race obstructed by pieces of thread.

Remedy

Oil machine as instructed in Chapters 3, 13 and 21.
Use only non-resinous and acid-free sewing machine oil.
Try to free the jammed thread as you rock the balance wheel back and forth. If this action should fail, dismantle the sewing hook as instructed in Chapter 13.



Pfaff, D 6750 Kaiserslautern
Postfach 3020/3040, Telex 045 753

Nr. 296-12-07 064 engl.

Ph. Pfeiffer's
Buchdruckereien und Verlage
6750 Kaiserslautern

Printed in West Germany 11/79

Adjusting alternating pressers of the Pfaff 145, 545, 546, 555, 596

Applies also to Pfaff machines 146, 335, 346, 195, 196, 543, etc.

(Training aid prepared for use in Pfaff's Mechanical Training Courses only).

1 The basic setting of the sewing and feeding mechanisms

- 11 If the alternating pressers are combined with compound feed, adjust the machine at first as instructed in "Sewing and Feeding Mechanisms of Pfaff 141".
 - 12 If the alternating pressers are combined with drop feed, adjust the machine at first as instructed in "Sewing Mechanism Pfaff 134" and "Feeding Mechanism Pfaff 134".
-

20 Position of the Alternating Pressers

- 21 When the presser bar lifter is raised, there should normally be a clearance of an amount between the sole of the lifting presser and the surface of the needle plate.

The amount of fabric clearance varies with the machine model, and for C, D, and H machines, the amount of clearance should be looked up in special tables or in our Instructions for Mechanics. Model C and D machines are intended for heavier materials, while Model H machines feature a higher foot lift.

- 22 The amount of fabric clearance can be adjusted by raising the presser bar lifter and loosening the two binding screws in the presser bar position bracket. After the adjustment, both screws must be tightened securely.
 - 23 Secure the foot lift adjusting stud in the middle of the driving crank slot.
 - 24 Loosen the binding screws of the driving crank and adjust the driving shaft so that the vertical motion of the vibrating presser is halved by the sole of the raised lifting presser.
 - 25 Tighten the binding screws on the driving crank securely.
-

30 Foot Motion

- 31 Lower the presser bar so that the lifting presser rests on the needle plate.
 - 32 Set the lifting eccentric so that
 - 32.1 Both the needle and feed dog reach the goods at the same time (on compound-feed machines) or
 - 32.2 That the vibrating presser engages the feed dog when the feeding action commences (on rigid needle bar machines).
-

Adjustment Procedures for Pfaff Machines 141

Applies also to Pfaff machines 142, 120, 122, 151, 541, 542, 191, 192, 341, and 342

1. Adjusting the position of the feed dog

1.1. Lateral adjustment of the feed dog:

Adjust position of feed rockshaft endwise until feed dog is centered in feed slot of the needle plate.

1.2. Lengthwise adjustment of feed dog:

Adjust feed rock shaft in driving crank so that the feed dog will not strike the front or back end of the feed slot when the machine is set for its longest stitch, both forward and backward.

1.3. Adjust the feed dog so that its right and left tooth rows emerge from the feed slots in the needle plate simultaneously.

1.4. Vertical adjustment of the feed dog:

When at its highest position, the feed dog should show a full tooth above the needle plate. Special sewing conditions may necessitate a slight modification of this setting. If adjustment is required, rotate the crank on the feed lifting shaft, as appropriate.

2. Checking the straightness of the needle and its position in needle holder and needle hole.

2.1. The machine normally uses system 134 needles. Certain classes or subclass machines use different needle systems, which are indicated in the respective needle and thread chart.

2.2. Check straightness of needle.

2.3. Check (with your fingernail) to see that needlepoint is not damaged.

2.4. Check position of needle in needle holder:

2.4.1. Needle must be pushed into needle holder as far as it will go.

2.4.2. Long groove of needle should be on the opposite side from the sewing hook; needle eye should be positioned at right angles to plane of hook rotation.

2.4.3. The needle holder should hold the needle securely.

2.4.4. The needle should be centered in the needle hole. Adjustment is made by turning the rear crank on the needle bar frame shaft (below the eccentrics).

2.4.5. The needle should descend in a straight line with the needle bar motion. If it does not, check to see whether the needle holder or the needle bar is bent, and straighten the bent part.

3 Needle bar rise

3.0. General hints:

The term “needle bar rise” denotes the amount of needle rise that is required to form a loop of the proper size. This amount is measured in millimeters or inches from the lowest point of the needle stroke with the needle bar drive rotating in its normal direction.

When the needle bar has risen the required distance from the bottom of its stroke, the hook point should be opposite the centerline of the needle.

The amount of needle bar rise required to form the loop is depended on the size and quality of the thread used, the needle size, the type of sewing hook, the sewing speed as well as other factors. The needle bar rise of the Pfaff 141 normally is 1.6 mm, or 0.062 inch. For further particulars, please refer to a needle rise table or the instructions for mechanics.

Model A and B machines: 1.6 mm or 0.062 inch.

Model C machines: 2.0 mm or 0.078 inch.

Model D machines: 2.2 mm to 2.4 mm or 0.086 to 0.094 inch.

3.1. Set feed regulator on “0”.

3.2. Setting the amount of needle bar rise with the aid of a gauge:

3.2.1. Turn the balance wheel until the needle bar is at the lowest point of its stroke.

3.2.2. Slip the clamp of the needle rise gauge onto the needle bar above the needle holder.

3.2.3. Slip the gauge (for the amount of needle rise specified) onto the needle bar above the clamp and push clamp and gauge up until the gauge bears against the lower needle bar bushing and the balance wheel can be turned neither forward nor backward.

3.2.4. Pull out the gauge.

3.2.5. Turn the balance wheel in its normal direction of rotation until the clamp strikes the bottom of the lower needle bar bushing.

3.2.6. When the needle bar has risen to this position, the loop has reached its proper size and the hook point should be exactly opposite the centerline of the needle. The hook should be set close to the needle (for a rough setting of the lateral clearance between hook and needle: for further particulars, see Par. 5 below).

3.2.7. Prerequisite for adjustment the amount of needle rise is that both the needle bar and hook drive mechanisms have no excessive play and work smoothly.

4 Needle bar height:

When both the sewing hook and the needle are at the position indicated in par. 2.6 above, the bottom edge of the hook point should be positioned about 1.5 mm or 1/16 inch above the top of the needle eye. If adjustment is required, loosen the setscrew in the needle bar connecting stud and set the needle bar higher or lower, as appropriate. Then tighten the setscrew securely again.

5 Setting hook to needle:

With the needle bar set at the correct height and risen the required distance from the bottom of its stroke, there should be a clearance of about 0.1 mm or .004 inch between hook point and needle (which equals the thickness of a piece of paper). To adjust, reposition the hook saddle and the large bevel gear.

6 Adjustment of the needle guard

Having set the hook to the needle as instructed above, the latter should contact the needle guard lightly without being deflected. To this end, the needle guard should be bent accordingly.

7 Bobbin case opener

- 7.1. Insert the bobbin case base into the sewing hook.
 - 7.2. Screw on the needle plate, making sure though that the position finger on the bobbin case base enters the recess in the needle plate.
 - 7.3. Loosen the set screws to the right or left of the sewing hook and adjust the bobbin case lever fulcrum on the hook saddle so that the bobbin case base is rotated counter-clockwise, lifting it clear of the stop in the needle plate recess by half its amount of play. Tighten the screw securely again.
 - 7.4. Check and correct this setting after threading the machine. As you do this, make sure that the bobbin case opener opens a clearance gap for the thread to slop through be
 - 7.5. By no means must the bobbin case opener rotate the bobbin case base so that it strikes the opposite stop in the needle plate recess.
-

8 **Feed motion**

8.1. Feed lifting motion:

The rising feed dog and the point of the descending needle should reach the surface of the needle plate simultaneously.

8.2. Feed driving motion:

8.2.1. Set the machine for its maximum stitch length.

8.2.2. Adjust the feed driving eccentric on the arm shaft so that the needle bar (and the feed dog), after the needle has risen 0.6 mm from the lowest point of its stroke, will not make any perceptible motion as you move the feed regulator up and down between its ultimate positions (for the longest feed stroke forward and backward).

8.2.3. To obtain a more favorable feed motion, this basic setting may be modified slightly.

9 **Adjusting the position of the sewing foot.**

9.1. There should be a clearance of 6 to 7 mm, about ¼ inch, between the needle plate and the raised sewing foot. A larger clearance is possible for certain subclasses, provided a longer needle is used.

9.2. When the needle bar is at the lowest point of its stroke, the needle holder must not strike the raised sewing foot.

9.3. Orient the presser bar so that the needle is centered in the slot of the sewing foot.

9.4. When the sewing foot is lowered, its sole should rest on the needle plate evenly.

9.5. The presser bar should exert the full amount of pressure on the needle plate (the presser bar lifter has a slight amount of play when it is inoperative). Take a thin piece of paper or a piece of delicate material to check whether the sewing foot exerts the full amount of pressure and rests on the needle plate evenly.

9.6. The amount of pressure exerted by the sewing foot should be adapted to the type of fabric being sewn and the sewing speed. If the sewing foot pressure is set incorrectly, the following sewing troubles may occur.

(a) Pressure too strong: the material is damaged by the feed dog: the material is stretched along the seam line (seam puckering); the top and bottom plies are disarranged so that they will not finish out evenly

(b) Pressure too weak: the material may be damaged because it is not firmly engaged by the feed dog; at higher speeds, the material is not held securely so that accurate guidance is impossible; one ply creeps ahead of another; skipped stitches, irregular feeding.

10 Thread tension (general hints)

10.1. Bobbin thread tension:

The lower tension should be as weak as possible, yet clearly noticeable. Make sure that the bobbin thread can be pulled from the bobbin evenly, regardless whether the bobbin case is in the machine or has been taken out. Tension trouble may occur as a result of spring breakage, loss or slackness of the regulating screw, accumulations of dirt on the underside of the tension spring, damage of the bobbin or the bobbin case and knotty thread.

10.2 Needle thread tension:

The needle thread tension should be adjusted so that the needle and bobbin threads interlock in the center of the material, i.e. the concatenation of threads should lock the same top and bottom. This ensures maximum elasticity of the seam. The degree of needle thread tension is dependent on the bobbin thread tension, the fabric weight, the thread size, the setting of the thread check spring and feeding mechanism. As a rule, the needle thread tension should be as weak as possible in order to prevent puckering of the material and ensure maximum elasticity of the seam.

10.3 Tension release:

When the sewing foot is raised, the needle thread should pass through the upper tension lightly when pulled. When the sewing foot is lowered so that it rests on the material or the needle plate, the upper tension should be fully operative.

10.4 Thread check spring:

10.4.1 The thread check spring should be tensioned so that it will return to its stop smoothly and swiftly, yet with a certain power reserve. If the needle thread tension is weak, the thread check spring should likewise be set for a weak tension. And, conversely, when the needle thread tension is strong, the tension of the thread check spring should be increased or a more powerful spring be inserted.

10.4.2 The thread check spring stop should be set so that the spring is through acting when the needle point has reached the surface of a piece of material of normal thickness. A slight modification of this setting may become necessary either way.
